

TRIDON™

Technical Datasheet

17" SV616TALXU

431.8 mm

PN 10027999



CNPC
CNPC USA Corp.

PRODUCT SPECS

Cutter Size:	16mm
Cutter Back Up:	13mm (38 count)
Total Cutter Count:	129
Face Cutter Count:	67
Pin Connection:	7-5/8" API REG
Nozzle 1 qty/type:	9 /PZ25 Series
Nozzle 2 qty/type:	-
Junk Slot Area:	87.275 in ²
Gage Pad Length:	4" (101.6 mm)
Make Up Length:	-
Shank Diameter:	11.02" (279.9mm)
OFV Ratio:	61.5%
Shank/Sleeve Length:	-

APPLICATION

Tridon® bit series is a trouble free bit that delivers smooth torque, advanced directional control, excellent well bore quality, and dynamic stability. They are seamlessly compatible with multiple directional drive systems and their advanced gauge configuration options enables solutions to be continually developed for all offerings in the market.

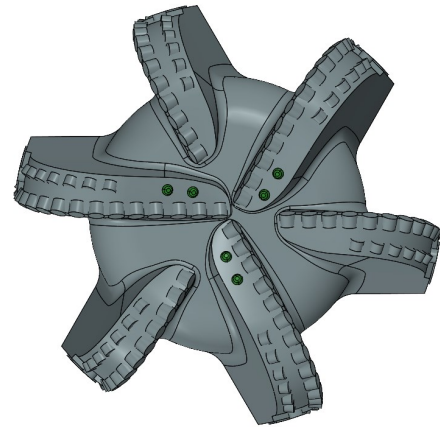

OPERATING PARAMETERS

Rotary Speed:	For all rotary and motor applications
Flowrate Min-Max:	650– 1750GPM (2.46 - 6.62m ³ /min)
Max Weight On Bit:	58,000 lbs (25800daN)
Makeup Torque:	68,600 - 84,750Ft-Lbs (93,009 - 114,906Nm)

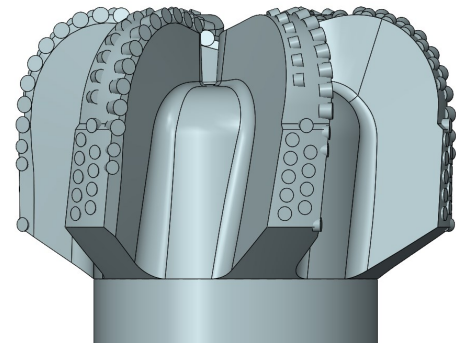

FEATURES

- T Tridon are optimized geometry cutters to increase ROP and durability in tough applications
- A Abrasion resistant cutters
- L Flat-top diamond inserts limit drill bit vibration and increase stability
- X Backup cutters reinforce durability
- U Up-drill Cutters

*Operating parameters shown are typical for the bit type specified.

For recommendations on your specific application, contact your CNPC USA representative.